



RiOs-DI™ 3 (UV) system
RiOs-DI™ Clinical system
User manual



Notice

The information in this document is subject to change without notice and should not be construed as a commitment by Millipore SAS. Millipore SAS assumes no responsibility for any errors that might appear in this document. This manual is believed to be complete and accurate at the time of publication. In no event shall Millipore SAS be liable for incidental or consequential damages in connection with or arising from the use of this manual.

We manufacture and sell water purification systems designed to produce pure or ultrapure water with specific characteristics ($\mu\text{S}/\text{cm}$, T, TOC, CFU/ml, Eu/ml) when it leaves the water purification system provided that the RiOs-DI Systems are fed with water quality within specifications, and properly maintained as required by the supplier.

We do not warrant these systems for any specific applications. It is up to the end user to determine if the quality of the water produced by our systems matches his expectations, fits with norms/legal requirements and to bear responsibility resulting from the usage of the water.

Copyright

© 2012 MILLIPORE SAS. PRINTED IN FRANCE. ALL RIGHTS RESERVED. THIS BOOK OR PARTS THEREOF MAY NOT BE REPRODUCED IN ANY FORM WITHOUT THE WRITTEN PERMISSION OF THE PUBLISHERS.

THE PHOTOS ARE NON-CONTRACTUAL.

FTPF09558

V.4.0 – 05/2012

Trademarks

Millipore, Millex, SmartPak, RiOs-DI and Milli-Q are registered trademarks of Merck KGaA.

RiOs and RODI are trademarks of Merck KGaA.

The "M" Mark is a trademark of Merck KGaA.

All other trademarks are trademarks of their respective manufacturers.

Product warranty and limitation of liability

The applicable warranty and limitation of liability for the products listed in this publication may be found at <http://www.millipore.com/ec/cp3/terms> within the "Terms and Conditions of Sale" applicable to your purchase transaction.



Directive 2002/96 EC: For European users only

The symbol "crossed bin" on a product or its packaging indicates that the product should not be treated like household waste when discarded. Instead the product should be disposed of at a location that handles discarded electric or electronic equipment.

Proper disposal of equipment containing electric or electronic components will help to reduce pollution effects to the environment or to human health. Proper recycling of these products helps in environmental preservation and helps to protect natural resources. For more information about recycling of products containing electric or electronic components, please contact your local recycling representative or organisation.

Table of Contents

Introduction	1
Using this Manual	1
Safety Information	1
Contacting Millipore® SAS	2
Product Information.....	3
RiOs-DI System Overview.....	3
RiOs-DI Product Water Specifications.....	3
Schematic of Main Components	4
Operating principle	4
Technical Specifications.....	5
Pre Installation	7
Installation Requirements.....	7
Optional Equipment You May Need	8
Unpacking the RiOs™-DI – What's Inside?.....	8
Installation	9
Preparation of the System	9
Connection of Tubing.....	9
Connection of the Power Cord – Turning on the System Power.....	12
Installation of the SmartPak	13
Installation of the Vent Filter	16
How to Show Resistivity or Conductivity Units (C01).....	17
How to Set the Resistivity Setpoint (C02).....	19
Using the RiOs-DI.....	21
Understanding the Display	21
How to Get Water from the RiOs-DI.....	21
Operating Modes	22
How to View the Product Resistivity and Temperature in Tank Full mode.....	24
How to View the RO Permeate Conductivity in Filling Tank mode or in Tank Full mode	24
How to Understand RiOs-DI messages	25
Maintenance	27
Maintenance Schedule	27
How to Replace the SmartPak.....	28
Flush Mode	30
How to Clean the Screen Filter	31

How to Calibrate the Tank Level (C03).....	33
How to Sanitize the Tank.....	35
How to Replace the UV Lamp (UV System only).....	39
How to View or Reset the UV Lamp Timer (C04).....	42
Troubleshooting.....	45
Ordering Information	47
Catalogue Numbers for RiOs-DI Systems.....	47
Catalogue Numbers for RiOs-DI Clinical System.....	47
Catalogue Numbers for Consumables.....	47
Catalogue Numbers for Accessories	47
Clinical kit	47

Using this Manual

This User Manual is a guide for use during the installation, normal operation and maintenance of a RiOs-DI 3 or a RiOs-DI 3 UV Water Purification System. 'RiOs-DI' is used in this manual to refer to either the RiOs-DI 3 or the RiOs-DI 3 UV unless otherwise noted. It is highly recommended to completely read this manual and to fully comprehend its contents before attempting normal operation or maintenance of the Water Purification System.

Safety Information

Your RiOs-DI System should be operated according to the instructions in this manual. In particular, the hydraulic and electrical specifications should be followed and met. It is important to use this equipment as specified in this manual; using this equipment in a different manner may impair the safety precautions of the RiOs-DI System.

Symbol

What it means



This HAZARD symbol is used to refer to instructions in this manual that need to be done safely and carefully.



This ATTENTION symbol is used to refer to instructions in this manual that need to be done carefully.



this UV RADIATION sticker is used to refer to a position on the system cabinet or inside of it where exposure to uv light is possible.



This DANGER sticker is used to refer to a position on the system cabinet or inside of it that could be hazardous.



this ELECTRICAL GROUND sticker is used to refer to a position on the system cabinet or inside where an electrical ground connection is made.



this ELECTRICAL DANGER sticker is used to refer to a position on the system cabinet or inside where an electrical danger could exist.

Introduction

Contacting Millipore® SAS

Internet

The Millipore SAS Internet Site can be used to find addresses, telephone/fax numbers and other information.

Internet Site Address: www.millipore.com
www.millipore.com/techservice
www.millipore.com/lab_water

Manufacturing Site

Millipore SAS
67120 Molsheim
FRANCE

RiOs-DI System Overview

The RiOs-DI produces purified water from potable tap water by combining several purification technologies. The Product Water is stored in an internal tank for routine laboratory applications, or it can be used to feed an ultrapure water purification system such as a Milli-Q®.

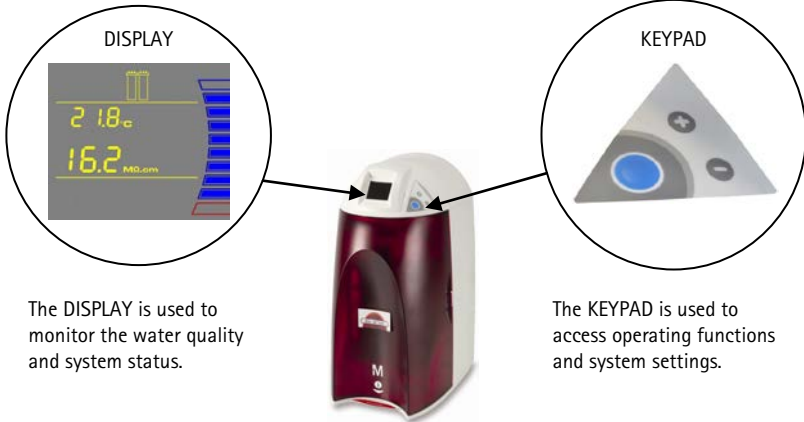

The DISPLAY is used to monitor the water quality and system status.

The KEYPAD is used to access operating functions and system settings.

RiOs-DI Product Water Specifications

Water Flowrate Specifications

PRODUCT WATER FLOWRATE	REJECT WATER FLOWRATE (5°C < T < 35°C)
> 2.4 LPH @ 15 °C (typical) > 3.5 LPH @ 25 °C (typical)	30 LPH

Product Water Quality

Resistivity	Typically > 10 MΩ.cm @ 25 °C
Conductivity	Typically < 0.1 μS/cm @ 25 °C
Total Organic Carbon (TOC)	< 50 μg/L (ppb)
Silica	> 90 %

Product Information

Schematic of Main Components

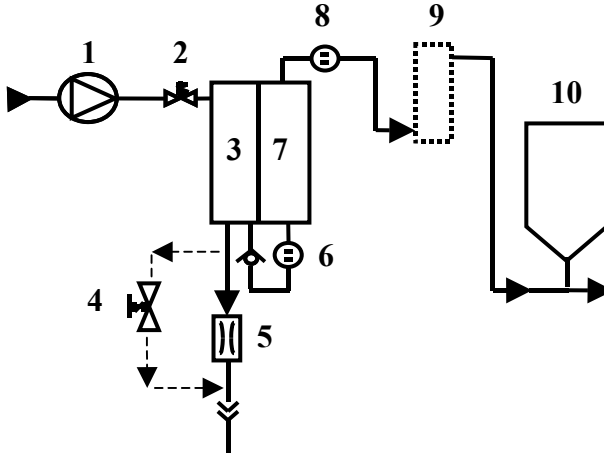

- | | | | |
|---|---|----|---|
| 1 | Booster Pump | 6 | Check Valve and RO Permeate Conductivity Cell |
| 2 | Inlet Solenoid Valve | 7 | SmartPak RODI (Ion Exchange Polisher Cartridge) |
| 3 | SmartPak® RODI™ (Pretreatment and RO Cartridge) | 8 | Product Resistivity Cell |
| 4 | RO Reject Solenoid Valve | 9 | UV Lamp 254 nm (UV System) |
| 5 | RO Reject Capillary | 10 | 6 Litre Tank |

Operating principle

Potable tap water enters the SmartPak RODI through the Booster Pump. The SmartPak RODI (called 'SmartPak' for the remainder of this manual) is an all-in-one twin-cartridge containing three water purification technologies. The first cartridge combines Pretreatment media and a Reverse Osmosis (RO) membrane. The second cartridge contains Ion Exchange resin. The SmartPak is a consumable device that needs to be periodically replaced during the maintenance of the system.

Tap water is pretreated to protect the RO membrane from organic fouling and chlorine oxidation. The RO membrane has 2 exiting streams. The RO water is sent to the Ion Exchange Polisher cartridge to deionize the water. The ions, particles, organic molecules and bacteria rejected by the RO membrane are sent to the drain via the Reject tubing.

The deionized water passes through the UV Lamp (UV System). The UV Lamp emits light at 254 nm. It is used to kill bacteria. The UV Lamp is a consumable device that needs to be periodically replaced during the maintenance of the system. Product Water is then generally stored for routine laboratory applications, or it can be used to feed an ultrapure water purification system such as a Milli-Q.

Technical Specifications

Dimensions

System Height, Width and Depth

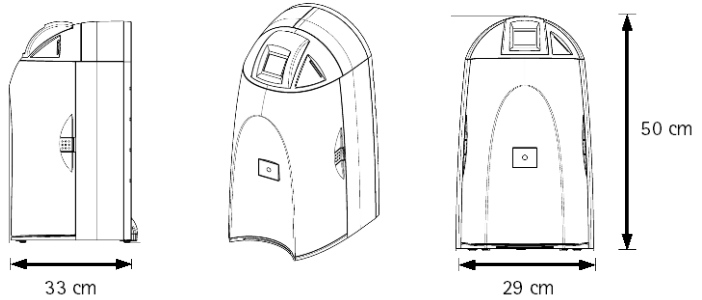

Shipping Box

- Height: 56 cm
- Width: 42 cm
- Depth: 64 cm

Weight

SYSTEM	RiOs-DI 3	RiOs-DI 3 UV
Operating Weight	16.8 kg	17.4 kg
Dry Weight	7.3 kg	7.8 kg
Shipping Weight	12.6 kg	13.1 kg

Noise Level

A RiOs-DI System has a maximum noise level of 36 dB at a distance of 1 metre away.

Electrical

- 100 VAC \pm 10%, 50/60 Hz. 0.68 amp source, 2 amp T (Time Lag) fuse, Power = 80 VA
- 120 VAC \pm 10%, 50/60 Hz. 0.60 amp source, 2 amp T fuse, Power = 80 VA
- 230 VAC \pm 10%, 50/60 Hz. 0.37 amp source, 2 amp T fuse, Power = 80 VA



The source of electrical power should be within 2.5 metres of the system. The source of electrical power must be earth grounded.

Installation Requirements

Feedwater Requirements

Type of Feedwater	Potable
Flowrate	≥ 40 LPH
Minimum Pressure	≥ 0.5 bar
Maximum Pressure	≤ 6 bar
Conductivity	< 2000 $\mu\text{S}/\text{cm}$
Temperature	5 to 35 °C
pH	4 - 10
Fouling Index	< 10
Iron	< 0.1 ppm as CaCO_3
Aluminum	< 0.05 ppm as CaCO_3
Manganese	< 0.05 ppm as CaCO_3
Free Chlorine	< 1 ppm
Langelier Saturation Index	$< +0.2$
TOC	< 2000 ppb

Feedwater Connection Needed

Feedwater Piping Connection	1/2 inch Male GAZ, NPTM or BSPM
-----------------------------	---------------------------------

Reject Flow Requirement

Drain Capacity	30 LPH
----------------	--------

Environmental Requirements

Indoor Use Only	
Storage Temperature	$5\text{ }^\circ\text{C} < T < 40\text{ }^\circ\text{C}$
Operating Temperature	$5\text{ }^\circ\text{C} < T < 40\text{ }^\circ\text{C}$
Relative Humidity	Should not exceed 80% for temperatures below 31 °C Should stay within 50% to 80% between 31 °C and 40 °C.
Altitude	< 3000 metres
Installation Category	II
Pollution Degree	2

Pre Installation

Optional Equipment You May Need

Wall Mounting Bracket

The Millipore SAS Catalogue Number for the Wall Mounting Bracket is WMBSMT001. The mounting hardware for attaching the bracket to a wall is not included and must be supplied.

Unpacking the RiOs™-DI – What's Inside?

Open the RiOs-DI System Shipping Box. Use the checklist included in the Accessories Bag to make sure all items were shipped and are accounted for. It is highly suggested to become familiar with the items that are shipped since these will be used in the Installation section of this manual.

Contact Millipore SAS if an item is missing.

Preparation of the System



- Open the front cover.
Locate the tie wrap used to hold the Booster Pump in place during shipping (A).



- Press on the tab of the tie wrap (B).
Remove and pull the tie wrap out.



- Locate the protective foam found at the UV lamp cable.
Remove it (C).

Connection of Tubing



- Rotate the RiOs-DI so you can see the back of the system (see photo A).

1. Feedwater tubing
2. Reject tubing
3. Overflow tubing
4. Tank outlet

Installation

Feedwater Tubing

B



- Locate the Feedwater Tubing exiting from the bottom middle of the system (B). A 1/2 inch Female GAZ fitting with a screen filter is attached at the end of this tubing. Unroll it until the fitting reaches the Feedwater source.
- Apply white tape on the thread of the 1/2 inch Male GAZ valve or fitting of the Feedwater source.

C



- Connect the fitting to the valve (C).

Reject Tubing

D



- Locate the Reject Tubing exiting from the bottom middle of the system (D). Unroll it.
- Secure the tubing into a sink or drain.

Overflow Tubing

E



- Locate the Overflow Tubing exiting from the bottom right of the system (E). Unroll it.
- Secure the tubing into a sink or drain.

Tank Outlet Tubing (RiOs-DI only)

F



- Locate the Tank Outlet Valve, the Tank Outlet Tubing and the adaptor fitting in the Accessories Bag.
 - Install the Tank Outlet Valve and Tubing as shown (F, G and H).
-

G



H



I



- Open the Tank Outlet Valve (I). This allows the tank to be emptied of any water in it. This is necessary when the SmartPak is flushed with water after it is installed.
-

NOTE:

For RiOs-DI Clinical, use the Clinical kit provided with the system to direct feed analyser.

Installation

Connection of the Power Cord – Turning on the System Power

A



- Open the front cover of the system (A). This will allow the system to go into STANDBY mode once the system is powered.
-

B



- Plug the Power Cord into the system (B).
 - Plug the other end of the Power Cord into an appropriate source of electrical power (i.e. wall outlet). The system is immediately powered.
 - Open the Feedwater Supply Valve.
-

Start-up Displays

C

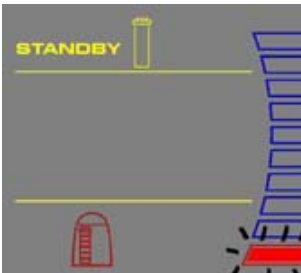

- Once the system is powered, the system will start to display information about the software before going into STANDBY mode (C).
-

Installation of the SmartPak



Open the Tank Outlet Valve before installing a new SmartPak. This keeps the tank from filling until the SmartPak is rinsed out (A).



Do not touch the UV Lamp when replacing the SmartPak.

Installation



-
- Make sure the front cover is opened.
-

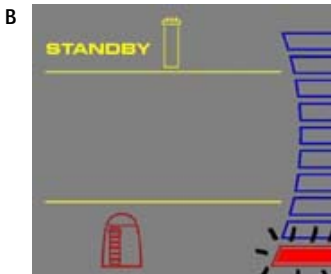

-
- STANDBY should be viewed on the Display (B).
 - Remove the SmartPak from its shipping box.
 - Remove the protective caps on the ports of the SmartPak and of the system.
-



-
- Locate the O-rings on the ports (C). Wet them with water. It is preferable to wet them with ultrapure water.
-

Installation

D



- Install the SmartPak until it is fully seated into the system ports as shown (D, E and F).

E



F



- CLOSE THE FRONT COVER.

G



NOTE:
The Tank Outlet Valve should be left open (G).

Flush Mode



The Tank Outlet Valve should be left open during FLUSH mode.



- The system will now go into FLUSH mode for 15 minutes (H). This is done to empty the SmartPak of air and hydrate the material inside.

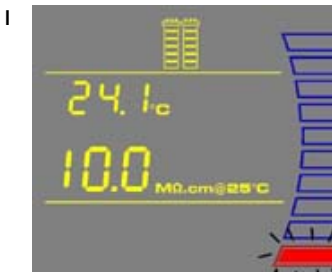

- When FLUSH mode is finished, the system will go into FILLING TANK mode automatically (I).

Rinsing the SmartPak



- Let FILLING TANK mode run for 15 minutes with the Tank Outlet Valve open. This will completely rinse the purification media inside the SmartPak.
- Close the Tank Outlet Valve (J). The tank will start to fill up with water. It could take approximately 1.5 to 2 hours to fill the tank. When it is full, the Display will indicate a full tank by illuminating the symbols representing the Tank Level (see *Section Understanding the Display*).
- The Vent Filter needs to be installed. See *Section Installation of the Vent Filter*.

NOTE:

for sensitive application, it is recommended to leave the system in FILLING TANK overnight.

Installation

Installation of the Vent Filter

A



- Obtain the Vent Filter.
 - Insert the Vent Filter firmly into the fitting (A, B).
-

B



How to Show Resistivity or Conductivity Units (C01)

With Temperature Compensated or non Temperature Compensated values

Temperature compensation is a way of 'standardizing' Resistivity or Conductivity to measurements that would be seen if the water temperature was 25 °C.

1



Press the Main and "+" Buttons together to enter the menu. The Display will show C01 and the units chosen. The following Display shows Temperature Compensated Resistivity Units: $M\Omega.cm @ 25\text{ }^{\circ}C$.



2



Press the "+" or "-" Button to select Non Temperature Compensated Resistivity Units: $M\Omega.cm$.

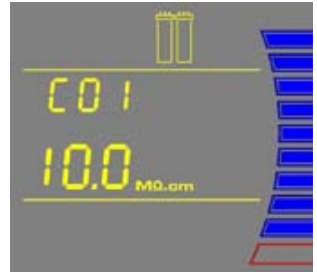

3



Press the "+" or "-" Button to select Temperature Compensated Conductivity Units: $\mu S/cm @ 25\text{ }^{\circ}C$.

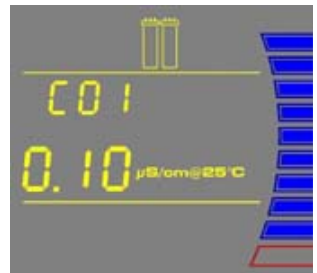

Installation

4



Press the "+" or "-" Button to select Non Temperature Compensated Conductivity Units: $\mu\text{S}/\text{cm}$.

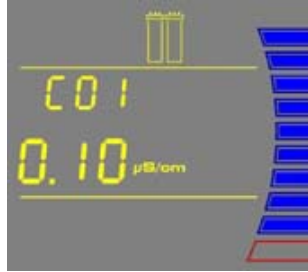

5



To exit the menu, press and hold the Main Button for 2 seconds.

To display the next menu option, press the Main Button once.

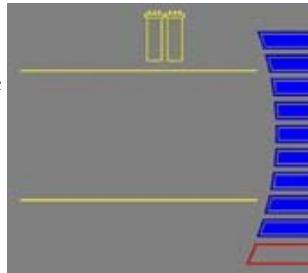

How to Set the Resistivity Setpoint (C02)

The Resistivity Setpoint is used to inform you when the Product resistivity is low. When the resistivity is below the setpoint, the Resistivity display will flash and the red Pack Alarm will be blinking (see *Section How to Understand RiOs-DI messages*). The factory default resistivity value is set to 15 M Ω . cm @25 °C.

1



Press the Main and "+" Buttons together to enter the menu. The Display will show C01.

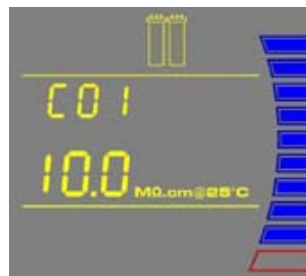

2



Press the Main Button once. The Display will show C02 and the Resistivity Setpoint value.



3



Press the "+" or "-" Button to adjust the Resistivity Setpoint from 1.0 M Ω .cm @25 °C to 9.0 M Ω .cm @25 °C.

If Conductivity Units are chosen in C01, then the Setpoint can be adjusted from 0.999 μ S/cm @25 °C to 0.111 μ S/cm @25 °C.

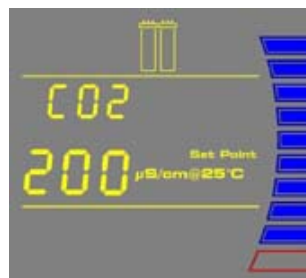

NOTE:

The Conductivity Setpoint display needs to be multiplied by 0.001 to get the real value. For example, if the Display reads "111" μ S/cm @25 °C, then you would multiply 111 x 0.001 = 0.111. Thus, the real Conductivity Setpoint reading is 0.111 μ S/cm @25 °C.

Installation

4



To exit the menu, press and hold the Main Button for 2 seconds.

To display the next menu option, press the Main Button once.

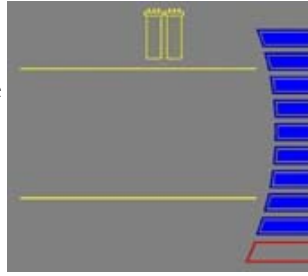

Understanding the Display

The Display is used to view information about the Operating Modes, the Operating Parameters, Maintenance or Alarm messages and the Tank Level.

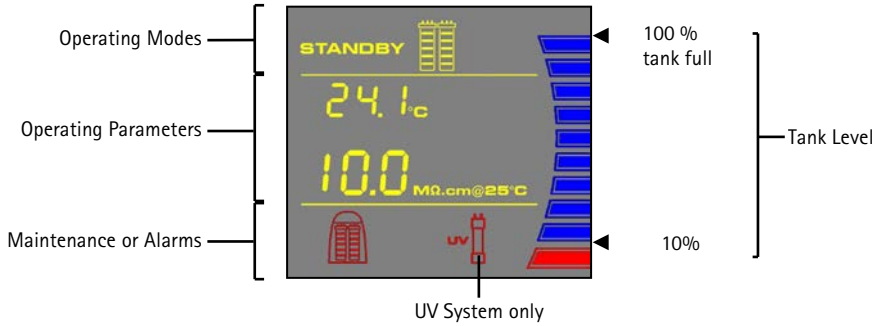

How to Get Water from the RiOs-DI

From the Tank Outlet Valve



- Product Water is obtained from the Tank Outlet. Open the Tank Outlet Valve when Product Water is needed (A).

Using the RiOs-DI

Operating Modes

Standby

STANDBY mode is displayed when the front cover is removed. The system will depressurize during which STANDBY will be blinking on the Display for 10 seconds. All system operations are disabled. STANDBY mode is selected before attempting maintenance on the system.

A digital display showing the word "STANDBY" in yellow, bold, capital letters on a dark background.

Flush

FLU (FLUSH) mode is displayed for 15 minutes after a new SmartPak has been installed and the front cover has been closed. FLUSH mode allows tap water to enter and rinse the new SmartPak. The Tank Outlet Valve must be opened during the FLUSH cycle to keep the tank from filling until the SmartPak is rinsed.

A digital display showing "FLU" on the top line and "15" on the bottom line, both in yellow on a dark background.

FLUSH mode is stopped if the front cover is removed to go into STANDBY mode. When the front cover is closed, FLUSH mode resumes from the last remaining time on the Display.

If the system is powered OFF during FLUSH mode and powered back ON, then a new FLUSH cycle will start.

The system will have a 2 minute FAST FLUSH cycle every 24 hours of TANK FULL mode.

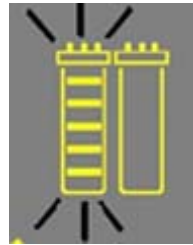

Filling Tank

FILLING TANK mode is displayed when the tank is being filled with Product Water until the 100% Tank Level display. FILLING TANK mode is launched automatically when the Tank Level display is below the 60% level or after a FLUSH cycle has been completed.



The resistivity and the temperature of the Product Water are automatically displayed during FILLING TANK mode.



Tank Full

TANK FULL mode is shown when the tank was full and has not been emptied below the 60% level. The tank is not being filled with water.

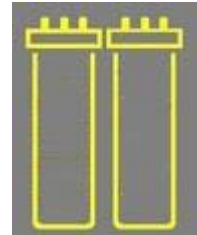

Using the RiOs-DI

How to View the Product Resistivity and Temperature in Tank Full mode

Press



The Display will show the last Product resistivity and temperature values measured during FILLING TANK mode. The values are displayed for 5 seconds.



NOTE:

The Product resistivity and temperature are displayed automatically during FILLING TANK mode.

How to View the RO Permeate Conductivity in Filling Tank mode or in Tank Full mode

Press



The Display will show the last RO Permeate Water conductivity value measured during FILLING TANK mode. The value is displayed for 5 seconds.

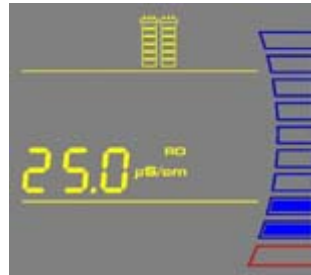

NOTE:

The units are displayed in $\mu\text{S/cm}$ only.

How to Understand RiOs-DI messages

Pack Alarm

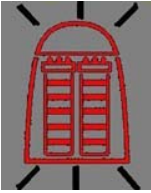

- The system will prompt you to change the SmartPak using a red Pack Alarm icon. The Display will show the red Pack Alarm blinking. The SmartPak is changed due to either the amount of time it has been used or from the amount of water that has passed through it.



- When the Resistivity display is blinking, the red Pack Alarm will also be blinking. This indicates that the SmartPak should be replaced. This message is shown when the Product resistivity is less than the Resistivity Setpoint. The Resistivity Setpoint can be seen in menu option C02.



- When the red Pack Alarm is displayed as a steady icon, the SmartPak is not installed correctly or not installed at all. If the SmartPak has been reinstalled and the Alarm is still displayed, then contact your technical support.

UV Lamp Alarm

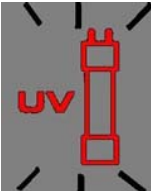

- The system will prompt you to change the UV Lamp using a red UV Lamp Alarm icon. The Display will show the red UV Lamp Alarm blinking. The message is shown when the UV Timer displays 0 days. The UV Timer can be seen in menu option C04. The replacement of the UV Lamp involves the installation of a new UV Lamp and a manual reset of the UV Timer.



- When the red UV Lamp Alarm is displayed as a steady icon, the UV Lamp is not installed correctly or not installed at all. If the UV Lamp has been reinstalled and the Alarm is still displayed, then contact your technical support.



Using the RiOs-DI

Flush: Open Tank Outlet Valve

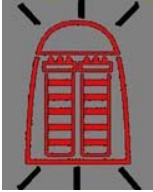

- Before FLUSH mode starts, the tank has to be emptied of water. The FLU counter display will be blinking if the system has detected that there is water in the tank. The Tank Outlet Valve must be opened. The system will automatically resume FLUSH mode when the tank is emptied of water.
-

Maintenance Schedule

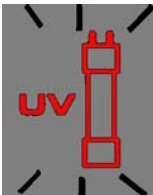
What to do	When?	How to?
<p>SmartPak Replacement</p>	<p>When the Pack Alarm display is blinking.</p>  <p>When the system resistivity display is blinking.</p>  <p>After a tank sanitization.</p>	<p>See Section How to Replace the SmartPak</p>
<p>Vent Filter Replacement</p>	<p>Replaced when the SmartPak is replaced.</p>	<p>See Section Installation of the Vent Filter</p>
<p>Tank Level Calibration</p>	<p>Periodically.</p>	<p>See Section How to Calibrate the Tank Level (C03)</p>
<p>UV Lamp Replacement and UV Timer Reset</p>	<p>When the UV Lamp Alarm display is blinking.</p> 	<p>See Sections How to Replace the UV Lamp (UV System only) and How to View or Reset the UV Lamp Timer (C04).</p>
<p>Screen Filter Cleaning</p>	<p>2 times a year or as necessary.</p>	<p>See Section How to Clean the Screen Filter</p>
<p>Sanitization of the Tank</p>	<p>Once a year.</p>	<p>See Section How to Sanitize the Tank</p>

Maintenance

How to Replace the SmartPak



Open the Tank Outlet Valve before installing a new SmartPak. This keeps the tank from filling until the SmartPak is rinsed out (A).



Do not touch the UV Lamp when replacing the SmartPak.

Removing the SmartPak

A



- Open the front cover to go into STANDBY mode. Wait for the system to depressurize. The Display will show STANDBY blinking for 10 seconds (A).

B



- Press your thumbs on the system (B).

C



- Swing the pack towards you and remove the pack from the system (C).

Installation



- Remove the new SmartPak from its shipping box.
- Remove the protective caps on the ports of the SmartPak.
- Locate the O-rings on the ports. Wet them with water. It is preferable to wet them with ultrapure water.
- Install the SmartPak until it is fully seated into the system ports as shown (D, E and F).

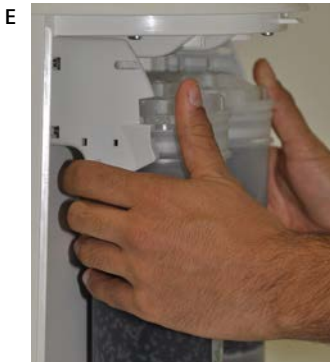

- CLOSE THE FRONT COVER.



NOTE:
The Tank Outlet Valve should be left open (G).

Maintenance

Flush Mode



The Tank Outlet Valve should be left open during FLUSH mode.

H



- The system will now go into FLUSH mode for 15 minutes (H). This is done to empty the SmartPak of air and hydrate the material inside.

I



- When FLUSH mode is finished, the system will go into FILLING TANK mode automatically (I).

Rinsing the SmartPak

J



- Let FILLING TANK mode run for 15 minutes with the Tank Outlet Valve open. This will completely rinse the purification media inside the SmartPak.
- Close the Tank Outlet Valve (J). The tank will start to fill up with water. It could take approximately 1.5 to 2 hours to fill the tank. When it is full, the Display will show the Tank Level filled to the 100% level.

NOTE:

for sensitive application, it is recommended to leave the system in FILLING TANK overnight.

Replacing the Vent Filter



- The Vent Filter should be replaced whenever the SmartPak is replaced.
- Remove the Vent Filter (K).
- Insert the new Vent Filter into the fitting. See *Section Installation of the Vent Filter*.

The System is now ready for use.

How to Clean the Screen Filter

The purpose of the Screen Filter is to prevent large particles or other debris from entering the system. If the Screen Filter becomes blocked with debris, then the Feedwater will not flow freely to the system.

It is recommended to clean the Screen Filter twice a year or whenever it may have become clogged.



- Close the Feedwater Supply Valve.
 - Open the front cover to let the system go into STANDBY mode.
 - Locate the Screen Filter. This will be located where the Feedwater 8 mm OD Tubing originates.
 - Unscrew the collar that holds the Feedwater Tubing to the barbed end of the fittings (A). Pull the tubing off of the fitting.
 - Unscrew the Screen Filter from the Feedwater pipe.
-



- Go to a sink and flush tap water backwards through the Screen Filter. The water should flow through the barbed end first. Any trapped debris on the Screen Filter will be flushed out (B).
 - Apply 3-4 turns of new white tape to the threads of the Feedwater Pipe in a clockwise direction.
 - Screw the Screen Filter back onto the Feedwater Supply Pipe.
-

Maintenance

C



- Attach the Feedwater Tubing back onto the Barbed Fitting (C).
 - Open the Feedwater Supply Valve.
 - Close the front cover.
 - Leave the system in FILLING TANK or TANK FULL mode.
-

How to Calibrate the Tank Level (C03)

Before calibrating the tank level, the tank needs to be filled to the 100% level or TANK FULL.

1



Press the Main and "+" Buttons together to enter the menu. The Display will show C01.

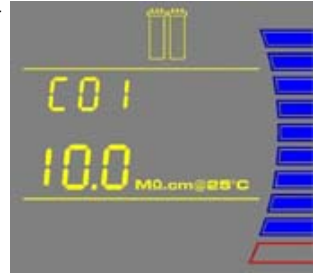

2



Press the Main Button 2 times. The Display will show C03. The highest Tank Level display will be blinking. This means that the highest water level is ready to be calibrated.

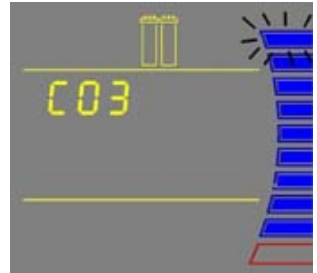

3



Press the "+" and "-" Buttons together to enter the highest water level. The Display will show the lowest Tank Level (red level) display blinking.

NOTE:

The highest and lowest tank level must be calibrated together or else the tank level is not calibrated.

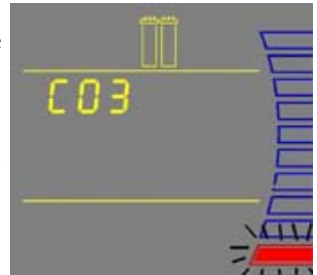

4



Open the Tank Outlet Valve. Allow the tank to be emptied to its lowest water level.

NOTE:

The lowest water level is not calibrated if the amount of water emptied from the tank is less than 10%.

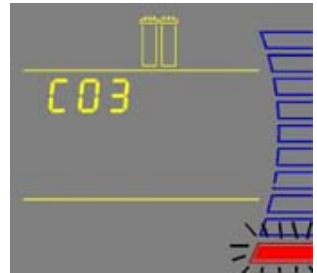

Continued on next page

Maintenance

5



Close the Tank Outlet Valve.

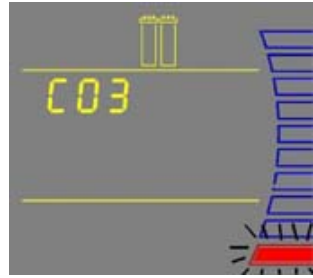

6



Press the "+" and "-" Buttons together to enter the lowest water level. The Display will exit the menu option and go into FILLING TANK mode.



The Tank Level is now calibrated.

NOTE:

If the Display remains in the menu option and the highest tank level is blinking, then the tank level was not calibrated. The amount of water emptied from the tank was not enough (less than 10%). The tank needs to be emptied to its lowest water level. Allow the tank to fill to the 100% level and perform the calibration again.

How to Sanitize the Tank

A tank sanitization is performed to eliminate bacteria growth in the tank. It is recommended to sanitize the tank at least once a year.

Things to Know BEFORE you sanitize the Tank



All safety precautions must be followed when handling Hydrogen Peroxide. Rubber gloves, safety goggles and a lab coat must be worn to avoid any skin and body contact.

A



- You will need a minimum Tank Level display of at least 50% (A).

B



- Locate the clear elbow fitting, the clear tubing and the syringe in the Sanitization Kit (B).
- You will need 200 ml of 30% of Hydrogen Peroxide solution and 200 ml of purified water. Millipore SAS does not sell Hydrogen Peroxide but it is readily available through most Scientific Supply Companies.
- The Vent Filter will need to be replaced after the sanitization is completed.
- The system will not be able to deliver Product Water while the system is being sanitized.



The total time needed to sanitize the tank is at least 4.5 hours.

Maintenance

Sanitizing the Tank

C



-
- Open the front cover to go into STANDBY mode (C).

D



-
- Remove the Vent Filter and install the clear elbow fitting from the Sanitization Kit (D).

E



-
- Introduce the male connector of the clear tubing firmly into the elbow fitting (E).

F



-
- Inject 200 ml (1 ml = 1 cc) of Hydrogen Peroxide solution (30%) into the 6 Litre tank via the clear tubing (F).
 - Rinse the air vent port with 200 ml of purified water.
-



- Close the front cover (G).
The system will now go into FILLING TANK mode.
-



- Let the Tank Level display go up to the 100% level (H).
-

Maintenance



- When the tank is full, open the front cover to go into STANDBY mode (I).
- Let the system stand for 1 hour for effective bacteria elimination.



- (After 1 hour) Check that the Tank Outlet Tubing is secured into the drain. Open the Tank Outlet Valve to drain all the water from the tank (J).

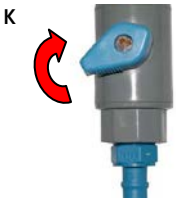

- Close the Tank Outlet Valve (K).



- Close the front cover (L). The system will now go into FILLING TANK mode. Let the tank level fill up to the 100% level.

Repeat steps I, J, K and L:

- Open the front cover to go into STANDBY mode (I).
- Check that the Tank Outlet Tubing is secured into the drain. Open the Tank Outlet Valve to drain all the water from the tank (J).
- Close the Tank Outlet Valve (K).
- Close the front cover (L). The system will now go into FILLING TANK mode. The tank is now sanitized.

How to Replace the UV Lamp (UV System only)

The red UV Lamp Alarm will be blinking on the Display when it is time to exchange the UV Lamp. The message is shown when the UV Timer has reached 0 days (see *Section How to View or Reset the UV Lamp Timer (C04)*).



No electrical power should be going to the system at this time. Accidental exposure to ultraviolet light can cause damage to the eyes and skin.



- Open the front cover to go into STANDBY mode (A).



- Unplug the electrical cord to power OFF the system (B).



- Remove the SmartPak (C).

Maintenance

Removing the UV Lamp

D



- Detach the Velcro® belt of the UV housing.
- Pull the UV housing out so that the UV Lamp cable is accessible (D).

NOTE:

Use the gloves supplied with the UV replacement kit.

E



- Pull the UV Lamp out of the UV housing by its electrical cable (E).

F



- Unplug the electrical cable from the UV Lamp (F).



The UV Lamp contains metallic Mercury. Please dispose of the used UV Lamp in a manner that is environmentally safe.

Installing the new UV Lamp

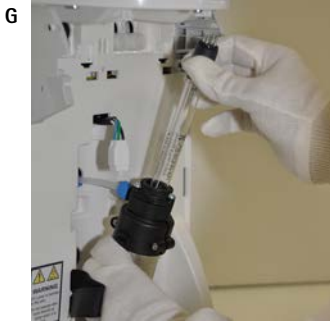

- Ensure that you use the gloves supplied with the UV replacement kit. Plug the electrical cable to the new UV Lamp (G).



- Carefully insert the UV Lamp into the UV housing (H).



- Attach the UV housing with the Velcro belt (I).



- Install the SmartPak (J).



ATTENTION

If the SmartPak is not being replaced, then reinstall the old SmartPak **BEFORE** powering **ON** the system. Otherwise, the system will go into **FLUSH** mode for 15 minutes during which no Product Water will be available.

- Close the front cover.
- Plug the electrical cord to power **ON** the system.
- Reset the UV Timer. See *Section How to View or Reset the UV Lamp Timer (C04)*.

Maintenance

How to View or Reset the UV Lamp Timer (C04)

The UV Lamp Timer should be reset only after the UV Lamp has been replaced (*see Section How to Replace the UV Lamp (UV System only)*). The UV Lamp Timer displays the time left until the UV Lamp needs to be replaced. The Display will show the red UV Lamp Alarm icon blinking when the Timer reaches 0 days. This message is displayed until the UV Lamp is replaced and the UV Lamp Timer is reset.

How to View the Remaining Days on the UV Lamp Timer

- 1 Press the Main and "+" Buttons together to enter the menu. The Display will show C01.

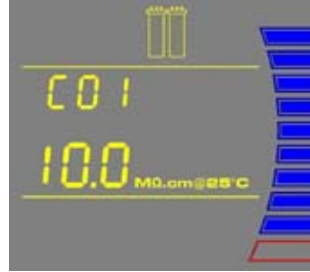

- 2 Press the Main Button 3 times. The Display will show C04 and the days left on the UV Timer.



- 3 To exit menu, press and hold the Main Button for 2 seconds.



To display the next menu option, press the Main Button once.

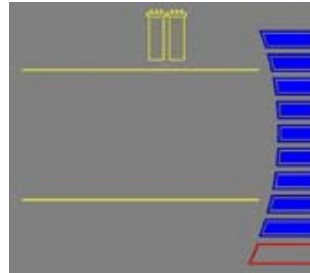

How to Reset the UV Lamp Timer

1



Press the Main and "+" Buttons together to enter the menu. The Display will show C01.

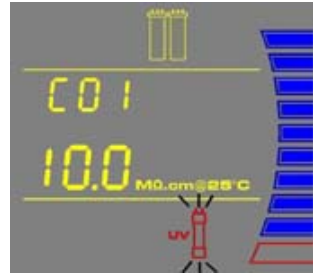

2



Press the Main Button 3 times. The Display will show C04 and "0" days left on the UV Timer.

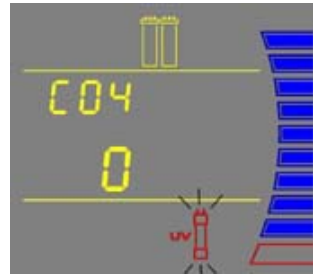

3



Press the "+" and "-" Buttons together. This will reset the UV Timer to 500 (days). The Display will exit the menu.

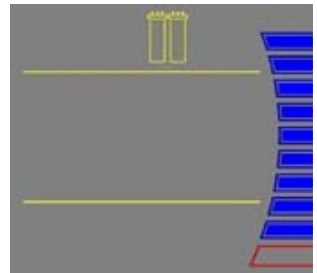



The UV Timer has been reset.

Troubleshooting

Problem	Possible causes	What to do
The Display screen is blank.	<ul style="list-style-type: none"> • The power cord is not plugged in. • No source of electrical power. • Main Power Fuse is blown. 	<ul style="list-style-type: none"> • Check that the power cord is plugged in. • Check the source of electrical power. • Contact your technical support.
In FILLING TANK mode, the Tank Level display is not rising. (The Tank Level display should be rising steadily.)	<ul style="list-style-type: none"> • The Tank Outlet Valve is open. The water in the tank is diverted into the drain. No water is kept in the tank. • The tank level is not calibrated properly. • The RO membrane is dirty or clogged. 	<ul style="list-style-type: none"> • Close the Tank Outlet Valve. • Check the Feedwater source. • See <i>Section How to Calibrate the Tank Level (C03)</i>. • Replace the SmartPak.
The last RO Permeate conductivity value is not displayed when you press the "+" button.	<ul style="list-style-type: none"> • The measurement was not made during FILLING TANK mode. • The value is out of measurement range. 	<ul style="list-style-type: none"> • Allow the system to go into FILLING TANK mode to start a RO Permeate conductivity reading again.
The last Product resistivity value is not displayed when you press the "-" button in TANK FULL mode.	<ul style="list-style-type: none"> • A measurement was not made during FILLING TANK mode. • The value is out of measurement range. 	<ul style="list-style-type: none"> • Allow the system to go into FILLING TANK mode to start a Product resistivity reading again.
	<ul style="list-style-type: none"> • The Tank Outlet Valve is not open. The system detects that there is water in the tank. The system will not resume FLUSH mode until the tank is emptied of water. 	<ul style="list-style-type: none"> • Open the Tank Outlet Valve to drain the water from the tank. • Check that the Tank Outlet Valve and Tubing are directed downwards into the drain.

Troubleshooting

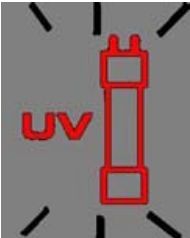
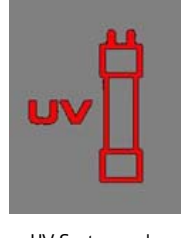
Problem	Possible causes	What to do
	<ul style="list-style-type: none"> The SmartPak lifetime is exhausted. The Product resistivity is less than the Resistivity Setpoint set in menu option C02. 	<ul style="list-style-type: none"> Replace the SmartPak. See <i>Section How to Replace the SmartPak</i>.
	<ul style="list-style-type: none"> The SmartPak is not installed correctly or not installed at all. 	<ul style="list-style-type: none"> Reinstall the SmartPak. If the red Pack Alarm is still displayed, then contact your technical support.
	<ul style="list-style-type: none"> The Product resistivity is below the Resistivity Setpoint set in menu option C02. 	<ul style="list-style-type: none"> Replace the SmartPak. See <i>Section How to Replace the SmartPak</i>.
 <p data-bbox="120 1082 253 1106">UV System only</p>	<ul style="list-style-type: none"> The UV Timer is exhausted. 	<ul style="list-style-type: none"> Replace the UV Lamp. See <i>Section How to Replace the UV Lamp (UV System only)</i>. After a new UV Lamp has been installed, reset the UV Timer. See <i>Section How to View or Reset the UV Lamp Timer (C04)</i>.
 <p data-bbox="120 1377 253 1401">UV System only</p>	<ul style="list-style-type: none"> The UV Lamp is not installed correctly or not installed at all. 	<ul style="list-style-type: none"> Power OFF the system and reinstall the UV Lamp. If the red UV Lamp Alarm is still displayed, then contact your technical support.

Catalogue Numbers for RiOs-DI Systems

For 230 VAC, 120 VAC, 100 VAC:

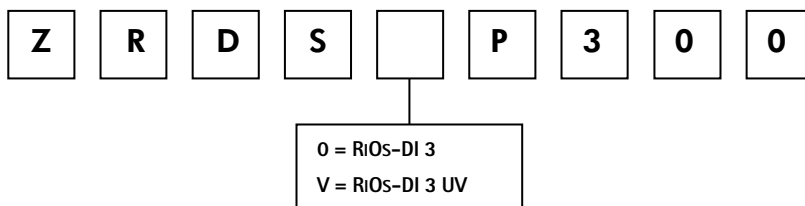

Catalogue Numbers for RiOs-DI Clinical System

For 230 VAC, 120 VAC, 100 VAC:



Catalogue Numbers for Consumables

Consumable Item	Catalogue Number
SmartPak RODI	SPR00SIA2
Millex® Vent Filter (1µm), 2/box	TANKMPK03
UV Lamp 254 nm	ZLXUVLP01

Catalogue Numbers for Accessories

Accessory Item	Catalogue Number
Wall Mounting Bracket	WMBSMT001

Clinical kit

Accessory Item	Catalogue Number
Connection Kit BTA 1	ZF3000321

Quick access to most common procedures

Contacting Millipore® SAS..... 2
How to Replace the SmartPak.....28
Replacing the Vent Filter.....31

